

Mini Lok All - Keyless

Exterior

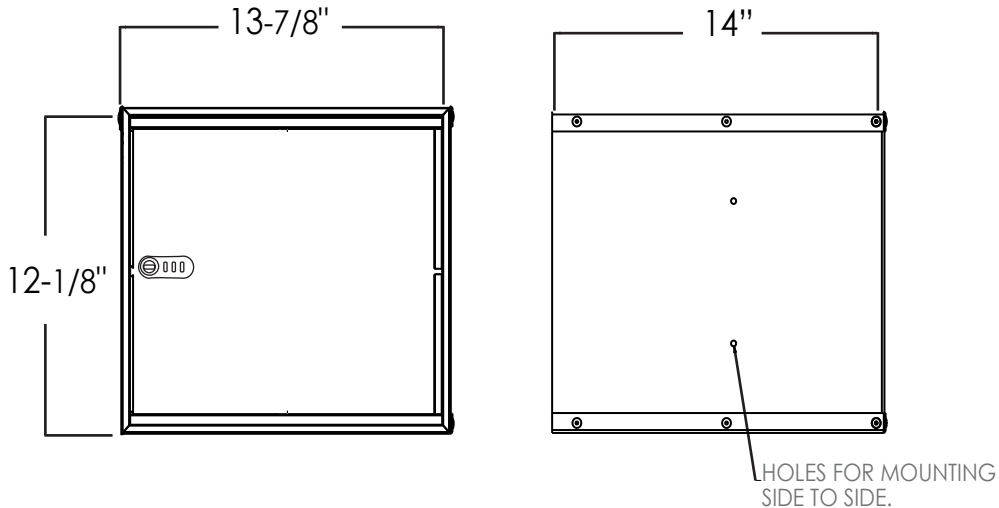

Mini-Lok All Keyed	Dimensions
Overall	12-1/8" x 13-7/8 x 14
1-Compartment	12-1/8" x 13-7/8 x 14
2-Compartment	5-1/8" x 13-7/8 x 14
4-Compartment	5-1/8" x 6-1/8 x 14

Interior Options

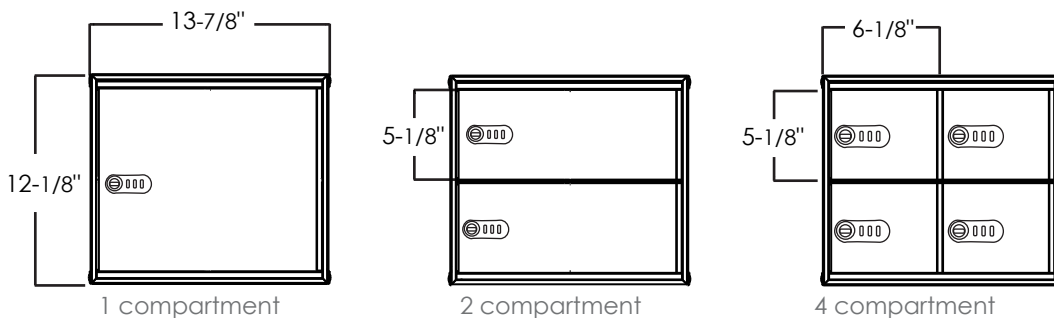

MATERIAL: Case fabricated of all aluminum extrusion and material finished in a powder coat finished case. Doors and door tracks are anodized extruded aluminum with a minimum thickness of 1/8" swing on continuous hinge.

LOCKS: Preinstalled zinc alloy mechanical lock with 1,000 possible combination codes. Codes resettable by each user. Two master keys provided to open locks and reset user codes.

FABRICATION: Lockers are shipped fully factory assembled. The design allows modules to be grouped together into a multiple-unit installation. Units may be flush mounted by installing in wall between studs.

GAUGES:

- Skin: .050" 5052-H-32 Aluminum.
- Shelves: .032" 5052-H-32 Aluminum.
- Uprights: .032" 5052-H-32 Aluminum.
- Doors: .100" 6063 Extruded Aluminum.
- Aluminum extrusion: 6063 Aluminum.

OPTIONS:

- 3/4" H permanent engraving.
- Black filled 3/4" H permanent engraving.
- 3 digit combination locks with key.

Mini Lok All Series

MODEL:	Mini Lok All		
MAT:	CRS Painted		
DWG#		SCALE:	
DATE:	10/22/07	BY:	er